

Wall Bracket Back-Box

LTB-110-BB

Suitable for Bracket series:

LTB301-U



Properties

Description	Wall Bracket Back-Box to suit (LTB301-U) Wall Bracket
Construction	Aluminum Alloy - Powdercoated - Rubber Flange Gasket
Dimension	180(L) x 120(W) x 60mm(H)
Weight	700g

Technical Specifications:

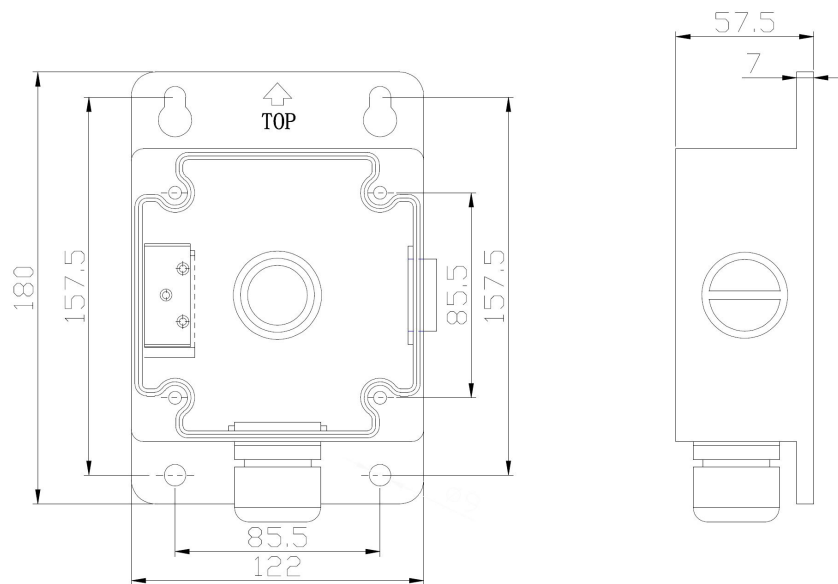

©2015 LT Security, Inc. All Rights Reserved. White papers, data sheets, quick start guides, and/or user manuals are for reference only and may or may not be entirely up to date or accurate based upon the version or models. Product names mentioned herein may be the unregistered and/or registered trademarks of their respective owners.