

# Slimline Vertical Mount Cabinet

## R-WM-3

### Key Features:

- Wall Mount Slimline Enclosure;
- 3RU - DVR/NVR/Switch
- Easy Cable Management
- Removable Side Panels
- Designed & Manufactured in Australia

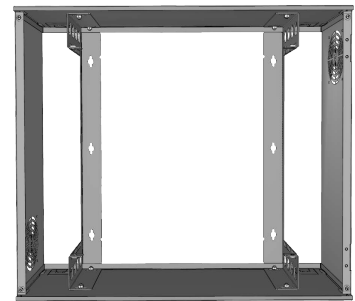

### Properties

Weight	11.4KG
Dimensions	600(H) × 250(D) × 690mm(W)
Material	Powder Coated Steel
Colour	Charcoal Black

### Dimensions:

