

S Touch-w/ S Touch-s
S Key-w/ S Key-s

User Manual

Split access control with intelligent secured power supply.



S Touch-w



S Key-w



S Touch-s



S Key-s

Contents

1. Introduction, features and specifications	01
2. Installation and Wiring Diagram	03
3. Manager Card Operation	11
4. User Settings	12
5. Alarm	13
6. Wrong input Keypad Lockout Function	14
7. To Reset to Factory Default	14
8. Sound and Light Indication	15
9. Master Setting	16
10. Advanced Application-Variuous Working Modes Application	22
10.1 Wiegand Reader Mode	24
10.2 Standalone access control for single door	28
10.3 Standalone access control for 2 doors I	29
10.4 Standalone access control for 2 doors II	30
10.5 Two units interconnected & interlocked for 2 doors	31
10.6 Anti-pass back function for single door	32
10.7 Anti-passback function for 2 doors	33
11. Simple Troubleshooting	34
12. Packing List	35

1. Introduction, features and specifications

1.1 Introduction

The sTouch-w/ sTouch-s/ sKey-w /sKey-s include access control unit and iBox (intelligent secured power supply), which are connected by wiegand bus. The access control unit has card reading and keypad operation functions, and the iBox provides power supply for the whole system, lock, alarm, ring bell, exit button and door contact.

The access control unit supports EM, HID, IC or CPU cards (available for different models), controls single or dual doors. There are 2 users zones in dual doors mode. It supports up to 2000 users in total, each user has one card and one PIN.

The access control unit supports 1 master code, one manager add card, one manager delete card, 1 anti-duress card and 1 anti-duress PIN, providing users with easy operation and safe guarantee.

1.2 Features

- sTouch-w/ sTouch-s/ sKey-w /sKey-s access control unit: Aluminium alloy structure, waterproof, fully potted, confirms to IP65
- Built-in intelligent secured switching power supply, input AC 100-240V or DC12-14V supply for both access control unit and electric lock.
- Split design of the control part, Wiegand bus transmit format, prevent the lock unlocked by strong magnetic, short circuit, open circuit or other illegal ways.
- Metal keypad(sKey-w /sKey-s) and touch panel(sTouch-w/ sTouch-s) optional.
- Built-in 125KHz (EM, HID card) or 13.56MHz(IC, CPU card, ISO14443A) reader.
- sTouch-w/ sTouch-s/ sKey-w /sKey-s access control unit: Digital backlit key, the back light can be set to Normal ON, Normal OFF or Human-Approach ON
- With door bell function, built-in or external door bell optional.
- Multi-function, operating as slave reader, single door, dual door, interlock. anti-pass back, etc, suitable for various occasions.

1.3 Specifications

1.3.1 Access control unit Specifications

Operating voltage range	DC 12V-14V (Supplied by the iBox)
Idle input current	≤35mA
Max proximity card read range	EM&HID card: 3-6cm IC&CPU card: 2-6cm
Excitation Frequency	125KHz or 13.56MHz
Card transmit format:	Wiegand 26-37
Keypad transmit format	4-6 digits key press to output card number format, 4 bits or 8 bits data.
Dimension	125×83×21.7 mm (s Touch-w / s Key-w)
	158×43×21.7 mm (s Touch-s / s Key-s)
Operating Temperature	-40 ~ 60° C (EM&HID card) , -20 ~ 60° C (IC or CPU card)
Operating Humidity	0-95%

1.3.2 iBox

Input Controller	AC 100-240V
Output Power	36W
Power Input Voltage	DC 12V-14V
Output current:	0.5A
Dimension	261×97×42 mm
Operating temperature range	-20° C ~50° C
Operating Humidity	0-95% (non-condensing)

2. Installation and Wiring Diagram (Before installation, please read the Quick Installation Guide carefully)

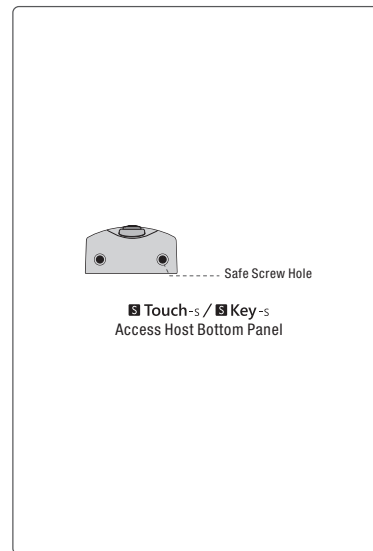
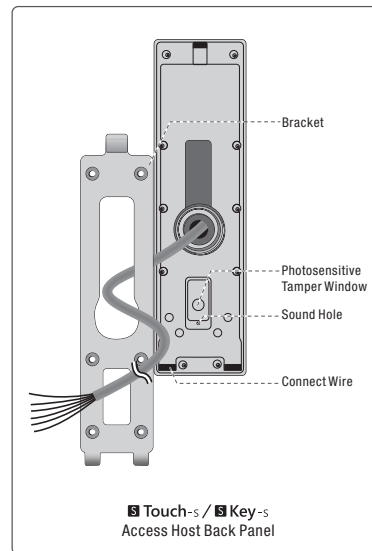
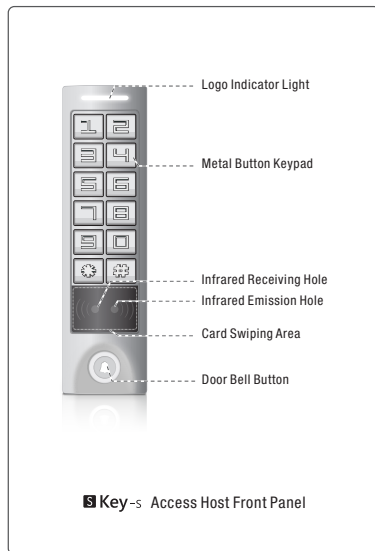

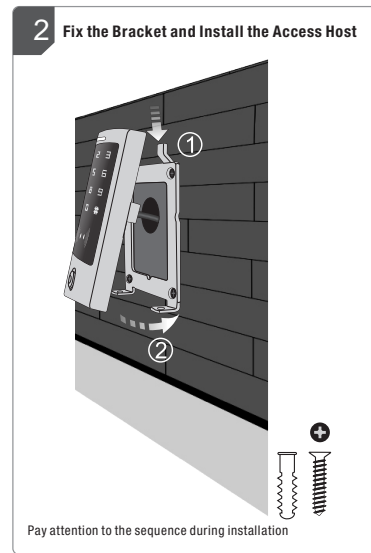
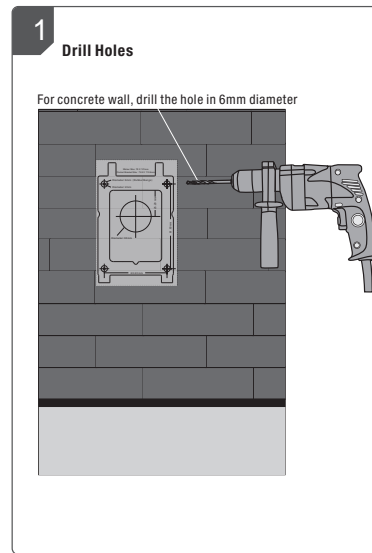
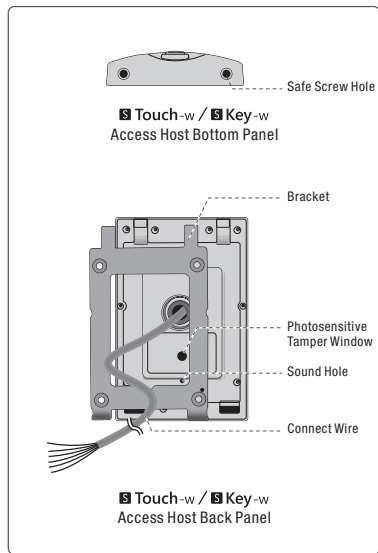

3

Fix Safe Screws

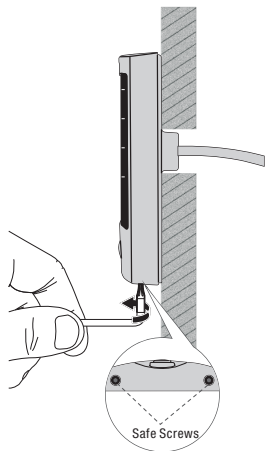

4

Install i Box and Exit Button

Diameter: 6mm (Rubber Bungs)

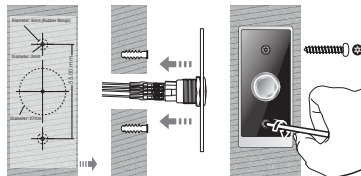
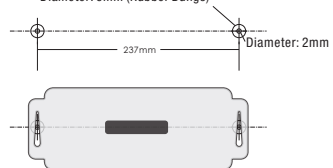

Before installing exit button, please read its user manual carefully

5

Install Lock

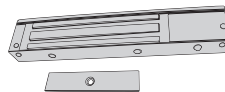

ⓘ Lock (not included in the package, please equip it locally)

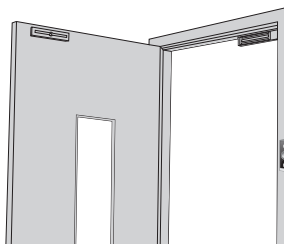

6

Wiring

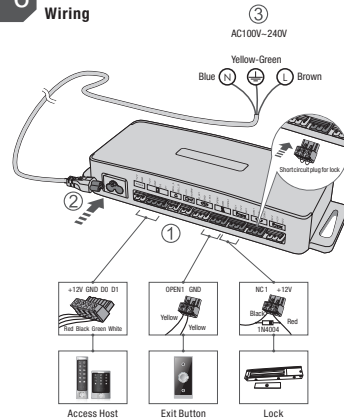

Remark: 1> Pay attention to the sequence when wiring, for different types of locks, please refer to their user manual
 2> For the indicator light of exit button, need to connect an extra 12V power supply

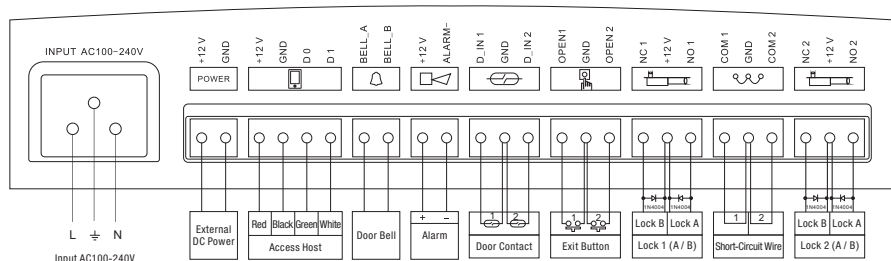

(Wiring Diagram)

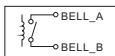

Principle of Door Bell Connector

Each press of door bell button, contact of relay in BELL_A and BELL_B will close contact for 200ms then release.

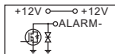

Principle of Alarm Connector

The field-effect tube will be conducted when alarm is activated; It will be not conducted when alarm is removed

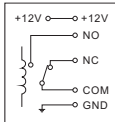

Principle of Electronic Lock

The relay will close contact to unlock the lock and will release after unlocking

COM: common, relay contact
 NC: normal close, normally keep closed to COM
 NO: normal open, normally keep opened to COM

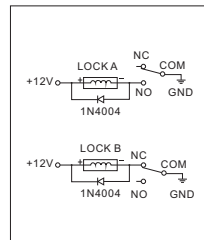

Wiring of electronic lock

Connect COM and GND, connect two ends of electronic lock with +12V and NO (or NC), complete the circuit.

Type A electronic lock: Fail Secure lock (Unlock when power on), such as Electronic Controlling Lock, smart lock. etc.

Type B electronic lock: Fail Safe lock (Unlock when power off), such as Electromagnetic Lock, Electronic Bolt Lock, etc.

1N4004 Diode: prevent high voltage to two ends of the electronic lock while the contact of relay disconnect. Without diode, there will be high voltage pulse interference to circuits and the life time of the relay will be greatly reduced.

Wiring diagram for different electronic locks (Wiring for one electronic lock as sample)

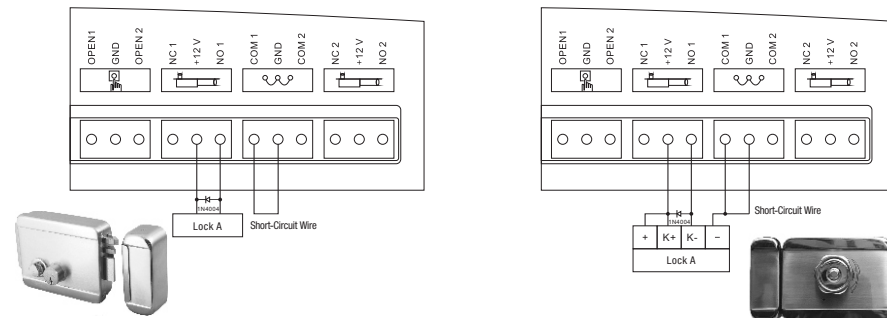

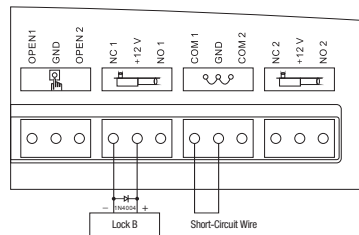
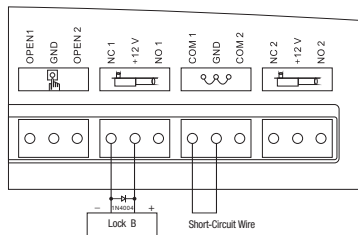

3. Manager Card Operation

3.1 Add user card(s)(In dual door mode, users can be only added to zone 1)

Read manager add card, Read one or more than one card continuously plan to add, Read manager add card

3.2 Delete user card(s)

Read manager delete card, Read one or more than one card continuously plan to delete, Read manager delete card

4. User Settings

4.1 To unlock the lock by one card: Read valid card once, the lock will be unlocked.

4.2 To unlock the lock for card and PIN users

Read valid card once Input 4-6 digits PIN #, the lock will be unlocked.

4.3 To unlock the lock for card or PIN users

Read valid card Or Input 4-6 digits PIN #, the lock will be unlocked

4.4 To unlock the lock for multi cards:

Read 2-10pcs valid cards (time interval can not exceed 5s), the lock will be unlocked

Precondition: Set the door entry by card only, and set "2-10" for opening the door by multi cards

4.5 Toggle Mode

In normal mode, Every time a valid card/tag read or PIN input, the relay will operate, for the pre-set relay pulse time.

Every time a valid card/tag read or PIN input in Toggle mode, the relay changes state, which will not turn back until read card/tag or input PIN again.

4.6 To change the PIN of a PIN user

* Read card Input old PIN # Input new PIN # Input new PIN #

Or

* User ID number Input old PIN # Input new PIN # Input new PIN #

Remark:

For users without card, must get ID number and initial PIN from the master. For Zone 1, the first digit of PIN must be "1", for Zone 2, the first digit of PIN must be "2"

For the card users with PIN "1234", must use Reading card to change the PIN for the first time.

4.7 Door Bell

Press the door bell button on the access control unit, the buzzer will sound ring back tone, at the same time, the iBox built-in door bell or the outer door bell will ring.

Remark: When the work mode is set in Auto Mode (Factory Default Mode), there will be no ring back tone without the Intelligent secured power supply.

5. Alarm**5.1 Anti Tamper Alarm**

When the access control unit is disassembled illegally, the access control unit's buzzer and the external alarm will operate.

5.2 Door Status Switch

When connect with door status switch, if the door is opened illegal, the access control unit's buzzer and the external alarm will operate.

5.3 Anti-duress alarm

When read zone 1 duress card / input 8digits duress PIN OR zone 2 duress cards / input 8digits duress PIN, then press #, the corresponding lock will open, at the same time, the external alarm will operate, but the access control unit's buzzer will not operate.

5.4 To remove the alarm

Read valid card or input master code can remove the alarm. If there is no operation, the alarm will remove automatically after 1 minute.

6. Wrong input Keypad Lockout Function

The Keypad will be Lockout if Input invalid master code, read invalid card, input invalid PIN or duress PIN, totally more than 10 times. There are 3 modes: wrong input times no limited, wrong 10 times will be lockout for 10 minutes, wrong 10 times will activate alarm for 1-3 minutes.

7.To Reset to Factory Default

Keypad access control(sKey-w, sKey-s), power off, keep pressing [*] and power on, the logo will turn in orange after 1 second, release it until hearing two short beep, then hearing a long beep, enter normal mode, reset to factory default setting is successfully.

Touch panel access control(sTouch-w,sTouch-s), power off, power on, the logo will turn in orange after 1 second, press [*] within 1 second, release it until hearing two short beep, enter normal mode, reset to factory default setting is successfully.

Remark: Reset to factory default, the users' information is still retained.

8. Sound and Light Indication

Operation Status	Logo Color	Buzzer
Standby	White	
Press Key		Short Ring
Read Card	Green	Long Ring
Unlock the lock	Green	Long Ring
Operation Successful	Green	Long Ring
Operation Failed		3 Short Ring
PIN Inputting	Slow Flash Red	
Card & PIN Reading	Slow Flash Red	
Multi Card Reading	Slow Flash Red	
1 st Menu	Slow Flash Red	
2 nd Menu	Slow Flash Orange	
Under Setting	Orange	
Manager Card Reading	Orange	2 Short Ring
Manager Card Exit	White	Long Ring
Alarm	Quick Shine in Red	Alarm
Ring-back Tone		Ding-Dong

9. Master Setting

Logo LED Light indication		Remarks	Functions
White logo	Red logo LED flash	Factory default :888888	To enter the programming mode
*	6-8 digits Master code #		

Enter Master Operation Mode. It will return to normal mode if there is no right Master PIN input in 5 seconds. After input of right master PIN, it will also return to normal mode if there is no valid operation in 30 seconds. Press “#” to confirm the input number, return to previous menu by press “*”, the logo light will indicate the operation mode.

Note that to undertake the following programming, the master user must be logged in

9.1 User Setting for Zone 1

Logo LED Light indication		Remarks	Functions
Red logo LED Flash	Orange logo LED		
0	New code # Repeat new code #	The master code could be any 6-8 digits number.	To change the master code
1	Read card	1. The user ID number is any number among 1 - 2000. 2. Card number must be 8 or 10 digits, if the card number is less than 8 or 10 digits, input 0 before the card number 3. Users can be added continuously without exiting programming mode	To add card users
	User ID number # read card		
	Card number #		
	ID number # Card number #		

1	User ID number # PIN #	<p>1. The user ID number is any number among 1- 2000.</p> <p>2. The PIN is any 4-6 digits exception of 1234 which is reserved (In the mode of Standalone for Two Doors and With External Reader for Two Doors, 1st digit must be 1)</p> <p>3. Users can be added continuously without exiting programming mode</p>	To add PIN users
2	Card number #	<p>Note: Users can be deleted continuously without exiting programming mode</p>	To delete card users by card number
	Read Card #		To delete Card users by cards.
	User ID number #		To delete Card or PIN users
	0000#	Delete ALL users for Zone 1 & 2	To delete ALL users
3	0 #	Entry is by Card ONLY	To set valid Card users
	1 #	Entry is by Card and PIN together	To set valid Card and PIN users
	2 #	Entry is by either Card or PIN (Factory default setting)	To set valid Card or PIN users
4	0 #	0 = 50mS	To set door relay time
	1-99 #	Door relay time:1-99 second, Factory default setting: 5	

Note:

① 8 digits card number, such as: 118, 32319, some cards has no mark of the first 3 digits 118, remains 32319, it requires to add card by read card, adding cards by input card number is not acceptable
 ② 10 digits card number, such as 0007765567, some cards have no mark of the first 3 digits 000, remains 7765567, requires to input 10 digits 0007765567 by add 000 before 7765567.

- ② A PIN 1234 is added for a card, it can not be used to unlock the lock, can be used to change PIN.
- ③ After one card is added, you can continue to add other cards or PIN without exiting the mode 1.
- ④ In mode of two Doors 1, the digit of PIN must be 1. Two doors 2, the 1 digit of PIN must be 2.
- ⑤ Delete all cards and PIN for both user zone 1 and zone 2.

9.2 Extended Function

Advanced Application(For Zone 1 only)				
Logo LED Light indication			Remarks	Functions
Red logo LED Flash	Orange logo LED Flash	Orange logo LED		
6	1	Read Manager Add Card		Set Manager Add Card
	2	Read Manager Delete Card		Set Manager Delete Card
	3	Read duress card	(Note: There are only one duress card and one PIN available. When input duress PIN/card, the door will open, at the same time, the external alarm operates.)	To set duress users
	4	8 Digits duress PIN #		
	5	0#	Relay Setting- Pulse mode(Factory default setting)	Relay setting
		1#	Relay Setting- Toggle mode	
2#		Relay Setting- Toggle mode		
6	1-10 #	Note: The door will open only when the valid card quantity up to the quantity set. It is only for Card ONLY Mode(Factory default setting: 1)	To set open door by multi cards	

6	7	User ID number # Card number # Card Quantity #	The card number must be consecutive Card quantity is between 1-2000	To add a series cards users-Block Enrollment
	9	1	Master unlocking 1	Administrator open door 1
		2	Master unlocking 2	Administrator open door 2
System Setting(For Zone 1 & Zone 2)				
7	0	0-15 #	Factory default setting:0	To set facility code
	1	0#	Wiegand reader	To set working mode
		1#	Standalone for single door	
		2#	Standalone for two doors	
		3#	With External reader for two doors	
		4#	Two units interlock for 2 doors	
		5#	Anti-passback for single door	
		6#	Anti-passback for two doors	
		9#	Automatic mode- Factory default setting	
		2	26-37 #	
	3	0#	Virtual card number	To set Keypad transmission
		1#	4-Bit	
		2#	8-Bit	
	4	0#	Alarm - OFF	To set alarm
		1-3#	ALARM-ON (Time can be set from 1-3 minutes, factory default :1)	
	5	0#	No door bell function	To set door bell function
		1#	Built-in door bell-ON(Factory default setting)	
		2#	External door bell-ON	
		3#	Built-in & external door bell-ON	

Option Setting				
8	1	0#	OFF-The device will be in silence except enter the programming mode	To set keypad tone ON or OFF
		1#	ON-The device will give the voice when press the keys (Factory default setting)	
	2	0#	No door bell function	To set door bell function
		1#	Built-in door bell-ON (Factory default setting)	
		2#	External door bell-ON	
		3#	Built-in & external door bell-ON	
	3	0#	Disable keypad backlight	To set keypad backlight
		1#	Enable keypad backlight (Factory default setting)	
		2#	Automatic mode Normally it is off (sleeping mode) but wake up with human approach.	
	4	0, #	Disable	To set anti-tamper alarm
		1, #	Enable (Factory default setting)	
	5	0, #	Normal status: No keypad lockout or alarm (Factory default)	Keypad Lockout & Alarm Output options. If there are 10 invalid cards or 10 incorrect PIN numbers in a 10 minute period either the keypad will lockout for 10 minutes or the alarm will operate, depending on the option selected below.
		1, #	Keypad Lockout	
		2, #	Alarm Output	

9.3 User Setting for Zone 2

Logo LED Light indication			Remarks	Functions
Red logo LED Flash	Orange logo LED Flash	Orange logo LED		
9	1	Read card	1. The user ID number is any number among 1- 2000. 2. Card number must be 8 or 10 digits, if the card number is less than 8 or 10 digits, input 0 before the card number 3. Users can be added continuously without exiting programming mode	To add card users
		User ID number # read card		
		Card number #		
		ID number # Card number #		
	User ID number # PIN #	1. The user ID number is any number among 1- 2000. 2. The PIN is any 4-6 digits exception of 1234 which is reserved (In the mode of Standalone for Two Doors and With External Reader for Two Doors, 1st digit must be 2) 3. Users can be added continuously without exiting programming mode	To add PIN users	
2	Card number #	Note: Users can be deleted continuously without exiting programming mode	To delete card users by card number	

9	2	Read Card #		To delete Card users by cards.
		User ID number #		To delete Card or PIN users
	3	0#	Entry is by Card ONLY	To set valid Card users
		1#	Entry is by Card and PIN together	To set valid Card and PIN users
		2#	Entry is by either Card or PIN (Factory default setting)	To set valid Card or PIN users
	4	0#	0 = 50mS	To set door relay time
		1-99#	Door relay time:1-99 second, Factory default setting: 5	

10. Advanced Application–Various Working Modes Application

Access host can work in 8 modes as below.

1. Wiegand reader
2. Standalone for single door
3. Standalone for two doors
4. With external reader for two doors
5. Two units interlocked for two doors
6. Anti-passback for single door
7. Anti-passback for two doors
8. Automatic mode (Factory default setting)

Application Scene Graph



Standalone for single door

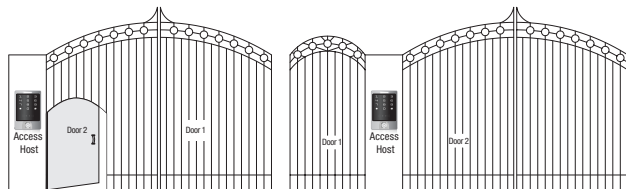

Standalone for two doors

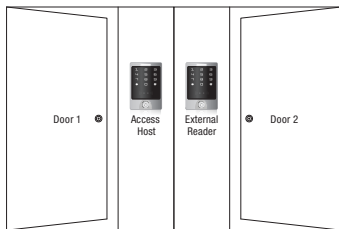

With external reader for two doors

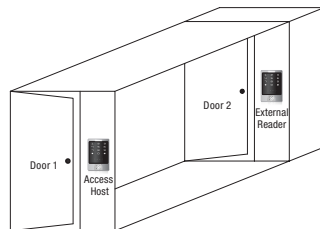

Two units interlocked for two doors

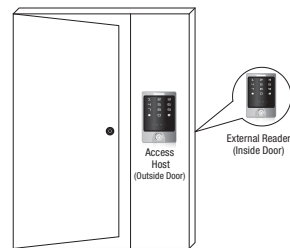

Anti-passback for single door

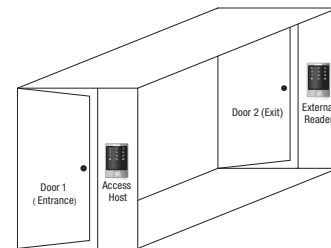

Anti-passback for two doors

10.1 Wiegand Reader Mode

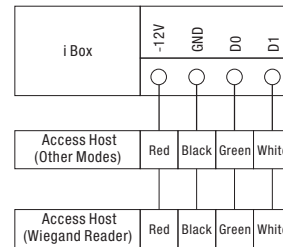
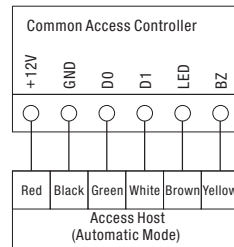

Both in auto mode or reader mode, the access host has Reader function.

While connected with common access control, it should be set to auto mode (Figure left), the access host will change to work as a reader.

While it is connected with another access host (not in reader mode), it should be set to reader mode (figure right)

The access host has functions as below as a reader:

Enter Master Operation Mode			
White	Flash Red	Functions	Remarks
*	6-8 digits master code, #	Enter master operation mode	Factory default :888888

Reader Settings				
Flash Red	Flash Orange	Orange	Functions	Remarks
0		6-8 digits master code, #, Repeat 6-8 digits master code, #	Change master code	
7	0	0-15, #	Set facility code	Default 0
	2	26-37, #	Card number output format	Default 26
	3	0, #	4-6 digits key press sends card number	Default 1
		1, #	Each key press sends a 4 bits data	
		2, #	Each key press sends an 8 bits data	
	4	0, #	Disable alarm ①	Default 1
		1-3, #	Enable alarm 1-3 minutes	
	5	0#	No door bell function	Default 1
		1#	Enable build-in door bell	
		2#	Enable external door bell	
3#		Enable both built-in and external door bell		

8	1	0, #	Logo indicator light Normal OFF②	Default 1
		1, #	Logo indicator light Normal On	
	2	0, #	Buzzer OFF③	Default 1
		1, #	Buzzer ON	
	3	0, #	Keypad backlit Normal OFF	Default 1
		1, #	Keypad backlit Normal On	
		2, #	Keypad backlit automatic mode ④	
	4	0, #	Disable anti tamper alarm	Default 0
1, #		Enable anti tamper alarm		

When the voltage of LED is low, logo light will turn into Green. When voltage of LED line is high, logo light will turn back to normal.

When the voltage of BZ is low, the Buzzer will beep, after 30 seconds or voltage of BZ is high, the Buzzer will turn back to normal.

When the access host worked as reader, both card number and keypad transmits in Wiegand format, the output data are shown by the Low Level of D0 & D1 cable:

D0: Low level means 0, green cable

D1: Low Level means 1, white cable

The wire in green (D0) is the wire for Wiegand 0, and the wire in white is the wire for wiegand 1. The pulse width for low voltage is 40uS; and the time interval is 2mS.

The digit of card number can be set to 26~ 37 bit and it should be matched with the controller. Factory default is 26 bit.

When you set it to 26 bit, the HID card will output wiegand 26–37 automatically as the format of the card, other card will output wiegand 26. when you set it to wiegand 27–37, all of the card will output wiegand 27–37 compulsively.

Facility code(1st-4th digits), range 0-15,0 will be added before the code if it is less than 4 digits, 4-6 digits PIN, 0 will be added before the PIN if it is less than 6 digits. For example, input facility code 15, password 999999, the output card number is 0015999999, the maximum card number is 0015999999(0xF423FF),it can be output in wiegand 26 card number format. and can be displayed by 10-bit decimal card number display equipment.

There are 3 formats output of card press:.

Format 0: 4-6 digits key press sends card number format: Input 4-6 digits PIN, press “#”, output a wiegand 26-37, 10-bit decimal card number. For example, input password 999999, the output card number is 0000999999, could be displayed by 10-bit decimal card number display equipment.

Format 1: Each key press sends 4 bits data, the corresponding relationship is:

1 (0001) , 2 (0010) , 3 (0011)
 4 (0100) , 5 (0101) , 6 (0110)
 7 (0111) , 8 (1000) , 9 (1001)
 * (1010) , 0 (0000) , # (1011)

Format 2: Each key press sends 8bit output data, the first 4 digits is ones-complement code for the last 4 digits, the corresponding relationship is:

1 (11100001) , 2 (11010010) , 3 (11000011)
 4 (10110100) , 5 (10100101) , 6 (10010110)
 7 (10000111) , 8 (01111000) , 9 (01101001)
 * (01011010) , 0 (11110000) , # (01001011)

10.2 Standalone access control for single door

The connection diagram is as below:

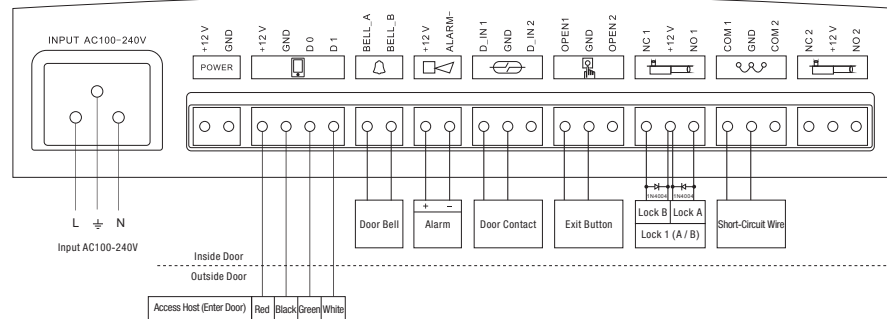

In this Mode:

Zone 1: When you swipe the card or type PIN which belong to Zone 1, or you swipe the card which belong to Zone 1 and Zone 2, the lock will open.

When you swipe the card/PIN for anti-duress, the lock will open, at the same time the external alarm will operate.

Zone 2, the users and the lock are invalid.

Can not add users, but can delete the users.

The function of external reader is the same as access control.

10.3 Standalone access control for 2 doors I

The connection diagram is as below:

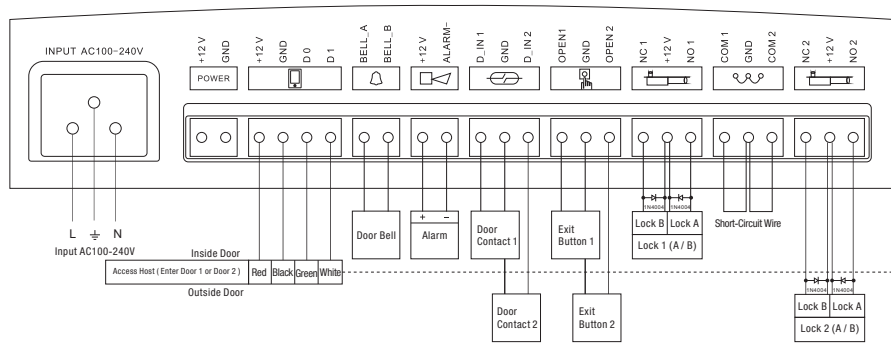

In this mode, the Access control Unit use for entering the doors, it supports connect external card reader for exit door.
 The users of Zone 1 of Access control Unit or external card reader can open the door of relay 1 by valid card or PIN.
 The users of Zone 2 of Access control Unit or external card reader can open the door of relay 2 by valid card or PIN.

10.4 Standalone access control for 2 doors II

The connection diagram is as below

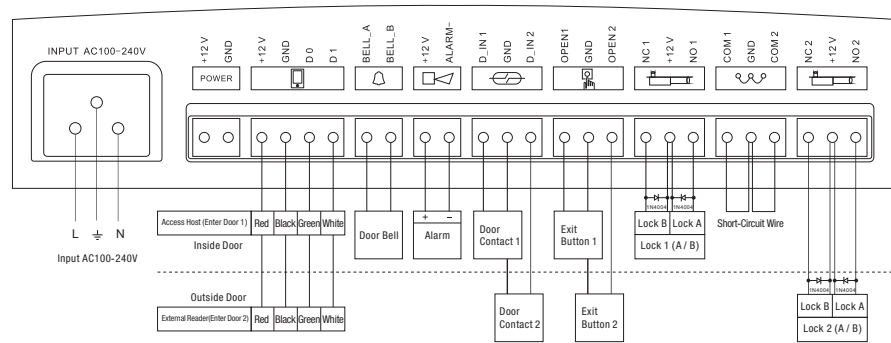

In this mode, the Access control Unit use for entering the doors, it support connect external card reader for exit door.
 The users of Zone 1 of Access control Unit or external card reader can open the door of relay 1 by valid card or PIN.
 The users of Zone 2 of Access control Unit or external card reader can open the door of relay 2 by valid card or PIN.

10.5 Two units interconnected & interlocked for 2 doors

The connection diagram is as below

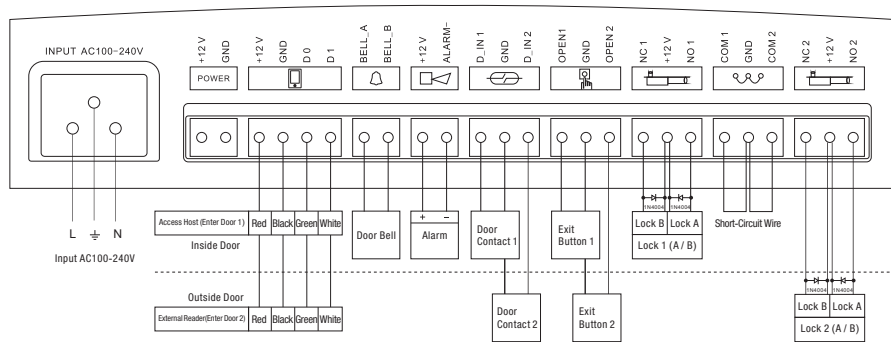

In this mode, two units are used for two doors which are interconnected and interlocked. Access control Unit for entry door 1, external card reader control door 2.

When the users of Zone 1 use the valid card/PIN to open door 1. door 1 is open, door 2 cannot be opened, and vice versa, The interlocked function is mainly used in banks, prisons, and other places where a higher level of security is required.

The users of Zone 2 is invalid.

10.6 Anti-pass back function for single door

The connection diagram is as below

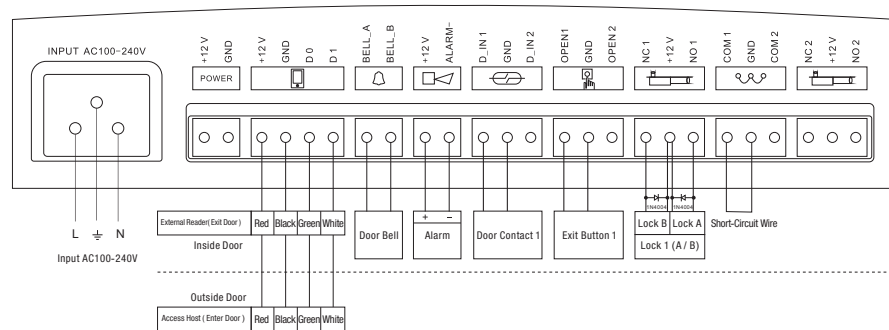

Install the Access control Unit outside the door acts as the Anti-passback Master unit, connecting the external card reader inside the door. Of the two devices, they build up an Anti-passback system for single door. The operation and function is as below:

Set the needed function and enroll the User Cards on the outside controller - Anti-passback Master unit.

With the valid user card, the user can only enter the door from the outside controller, and exit from the inside card reader. On the other hand, without entering record from the controller, the user can't exit from the reader inside; also, the user can't enter in and exit twice continuously.

Remark: This is only for Zone 1, and the door can be opened by card ONLY, the PIN is invalid.

10.7 Anti-passback function for 2 doors

The connection diagram is as below

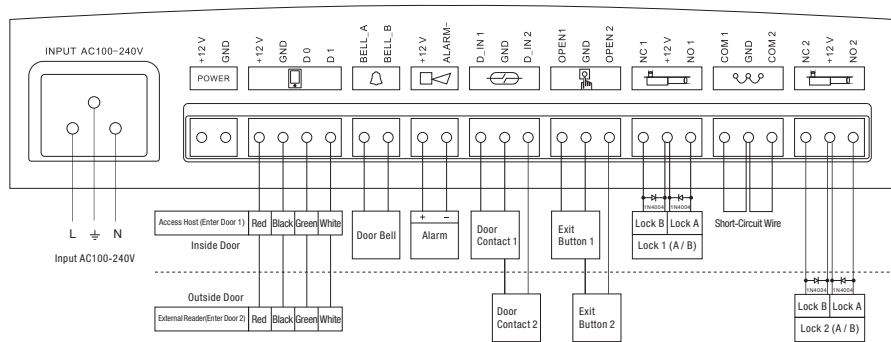

Anti-pass back for two doors: There are two doors, you have to enter via one door, and exit via the other. You should swipe your card both for entrance and exit.

Door 1 with the Access control Unit, and Door 2 with external card reader, the Access control Unit on Door 1 Anti-passback Master unit, and the card on door 2 as the Anti-passback Auxiliary unit. Then they build up a two doors Anti-passback system, which is normally used for parking lot...etc

The operation and function is as below:

Set the needed function and enroll the User cards from Access control Unit, - Anti-passback Master unit on Door 1.

With the valid user card, the user can only enter in from Door 1, and exit from Door 2. On the other hand, without entering record from the Auxiliary unit, the user can't exit from the Master unit or Auxiliary unit, also, the user can't enter in and exit twice continuously

Remark: This is only for Zone 1, and the door can be opened by card ONLY, the PIN is invalid.

11. Simple Troubleshooting

Fault Phenomenon	Fault Cause	Reason & Solution
Reading distance is too close	1. Card problem 2. Switch power supply interferences card reading	1. Please use original made card 2. Wiring power supply and access host shell to ground wire
Set user PIN failed	1. Wrong way of PIN setting 2. Setting PIN under card reading mode	1. In mode of two Doors 1, the 1st digit of PIN must be 1. Two doors 2, the 1st digit of PIN must be 2. 2. User PIN cannot be 1234 3. User PIN only can be 4~6 digits
Can't open door after inputting user's PIN	Use 1234 as user's PIN	1234 is the initial value, can't be used to open doors, unless after resetting them to other 4~6 digits
Alarm under normal situation	Light leaking when install access host	Leaning on wall closely when install access host
No reaction when reading card	not on standby status	Exit by pressing <input type="checkbox"/> until logo light turns to white
Keypad light off	Set keypad light mode improperly	1. Set the keypad light to always On or automatic mode 2. Under automatic mode, keypad light will on when people approaching

Cannot enter Administrator setting mode	Forget master code	Reset to Factory Default, default master code is 888888, need to reset conditions and specifications, but users' information is still retained
---	--------------------	--

For other issues beyond above, welcome to contact our technicians for more details.

12. Packing List

Name	Qty	Remark
S Touch / S Key	1	
User Manual	1	
Quick Use Guide	1	
Fixing Location Sticker	1	Used for locating installation position
Self Tapping Screw	4	∅3X20 mm
Rubber Bungs	4	∅6X24 mm
Diode	2	IN 4004 Diode
Manager Cards	2	Manager Add Card & Manager Delete Card
User Cards	3	EM Thin Card

Name	Qty	Remark
S Button	1	
User Manual	1	
Fixing Location Sticker	1	Used for locating installation position.
Self Tapping Screw	2	∅3X20 mm
Rubber Bungs	2	∅6X24 mm
Screw Driver	1	
Wire	4	Four Wires (Color: Yellow X2, Red, Black)

I Box	1	
Self Tapping Screw	2	∅4X25 mm
Rubber Bungs	2	∅6X30 mm
Power Connecting Wire	1	Length: 50 cm
Screw Driver	1	